

Exam 2 Solutions

Your name:

10/31/2013

1. (10 points). Consider a circular DHT with 27 nodes numbered 0, 1, ..., 26, where the nodes cache key-values pairs for 60 seconds before discarding them. Assume that each node i handles keys with hash values in the range $100i$ to $100i+99$. Also, assume that node i has routes to nodes $i+1$, $i+3$ and $i+9$ (where the additions are modulo 27). What is the maximum number of hops required to get from one server to another in this DHT?

Each step moves you closer to the target by 1, 3 or 9 hops. Since $26=9+9+3+3+1+1$, the maximum number of hops is 6.

Suppose that some client sends a *get* request to node 20 with a key string of “candy corn”, and that $\text{hash}(\text{“candy corn”})=1853$. If the request is handled by exactly 4 nodes in the DHT (including 20), which nodes are they?

$20+9=2 \pmod{27}$, $2+9=11$, $11+3=14$. So, the four nodes are 20, 2, 11 and 14.

Suppose node 13 has an entry for “candy corn” in its cache but no other nodes do. Now assume that every other node receives a *get* request for “candy corn”. How many of these requests does 13 handle? (Ignore any new cache entries that might be created in the process of handling these requests.)

Node 13 will handle the request if it first arrived at node 13, 10, 4, 1, 22 or 19. So, node 13 will handle 5 requests from other nodes, plus one more if you include a request sent to 13.

Repeat your answer to the last question assuming that node 2 has the cached entry for “candy corn”. (That is, how many of the requests would 2 handle in this case?)

Node 2 would only handle requests that arrive at node 2 or node 20. So 1 request from other nodes, plus the one sent to 2.

2. (10 points) The diagram below shows a DNS query from a host *A* to its local DNS server. The IP addresses of all hosts are shown in the diagram. The label “*Q(web.foo.edu)*” specifies the query string. Complete the diagram showing all packets sent to resolve the name and continuing through the opening of a TCP connection to the web site and the first GET request. All arrows that represent DNS queries should have a label of the form “*Q(a.b.edu)*” and replies should have a label of the form “*R(b.edu=2.3.7.11)*”. TCP connection packets should be labeled with the appropriate flags and HTTP packets with the request type. Assume that the local DNS server performs recursive processing and has nothing in its cache, while the others perform iterative processing. You may assume that all queries and responses are for *A* records.

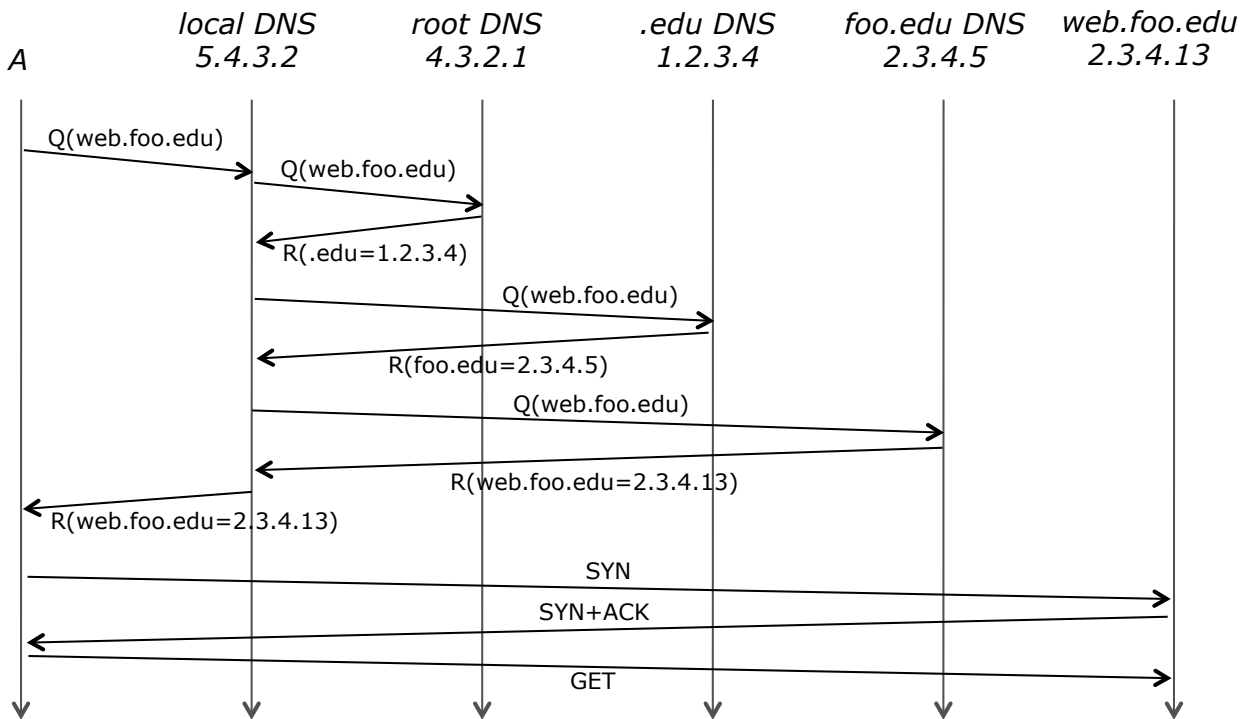

List all the mappings in the local DNS server’s cache after the query has been processed.

.edu=>1.2.3.4, foo.edu=>2.3.4.5, web.foo.edu=>2.3.4.13

List the mappings in the local server’s cache if the *.edu* server did recursive processing rather than iterative.

.edu=>1.2.3.4, web.foo.edu=>2.3.4.13

3. (10 points) The diagram at left below shows the state of the sending side of a communication session using a go-back- N protocol with cumulative acknowledgements, a window size of 4 and a retransmission timeout of 25. The array represents the “re-send” buffer and each pair in the buffer represents a packet and its sequence number, together with the time at which it is scheduled to be retransmitted (so, for example, the pair $(p3,14)$ denotes a packet with sequence number 3, which is to be retransmitted at time 14). Assume that the channel may lose packets but never re-orders them and that one way network delay is always at least 5 time units.

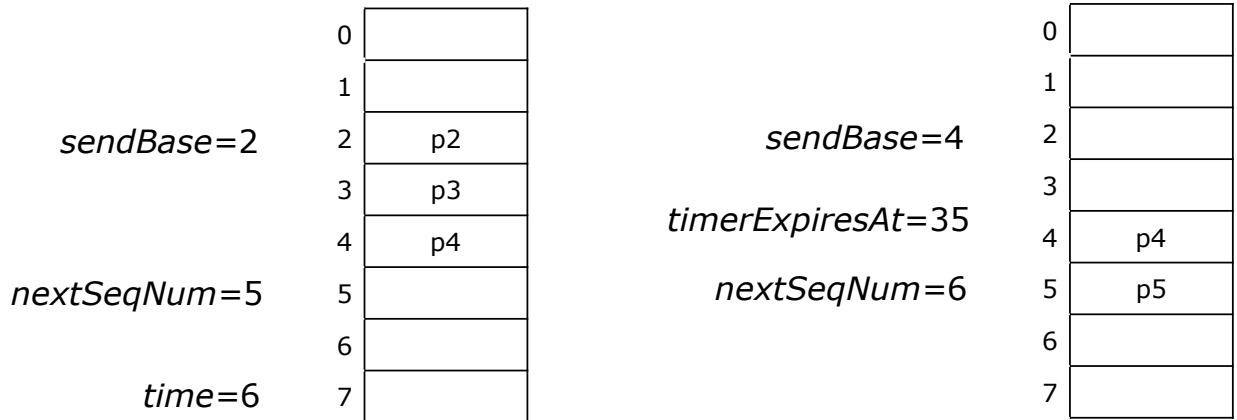

Suppose that at time 7, the application passes us a new payload to be sent and at time 12, we receive an ack with sequence number 3.

List all the packets sent by the sender between times 6 and 13, including repeats (if any).

$p5, p2, p3, p4, p5$

Show the state of the sender at time 13, in the right-hand diagram.

At time 12, how many additional packets can be sent before an ack is received?

2

4. (10 points) Consider a TCP sender that sends 10 bytes per packet. Suppose that the sender transmits six packets one right after another (including the one shown at right). Show the packets and the corresponding acks that TCP would return in a typical situation. Label the data packets with the sequence number and the ack packets with the ack number.

If the second of the acks is lost, will the sender retransmit any packets? Why or why not?

No, because the next cumulative ack lets the sender know that the corresponding packet was delivered.

Continuing the example, suppose that the next two packets sent arrive out of order and that the sender transmits four more packets after these and that the second packet in this group of four is lost. Extend the diagram to show these packets and the resulting acknowledgements. You need not show the retransmission of the lost packet.

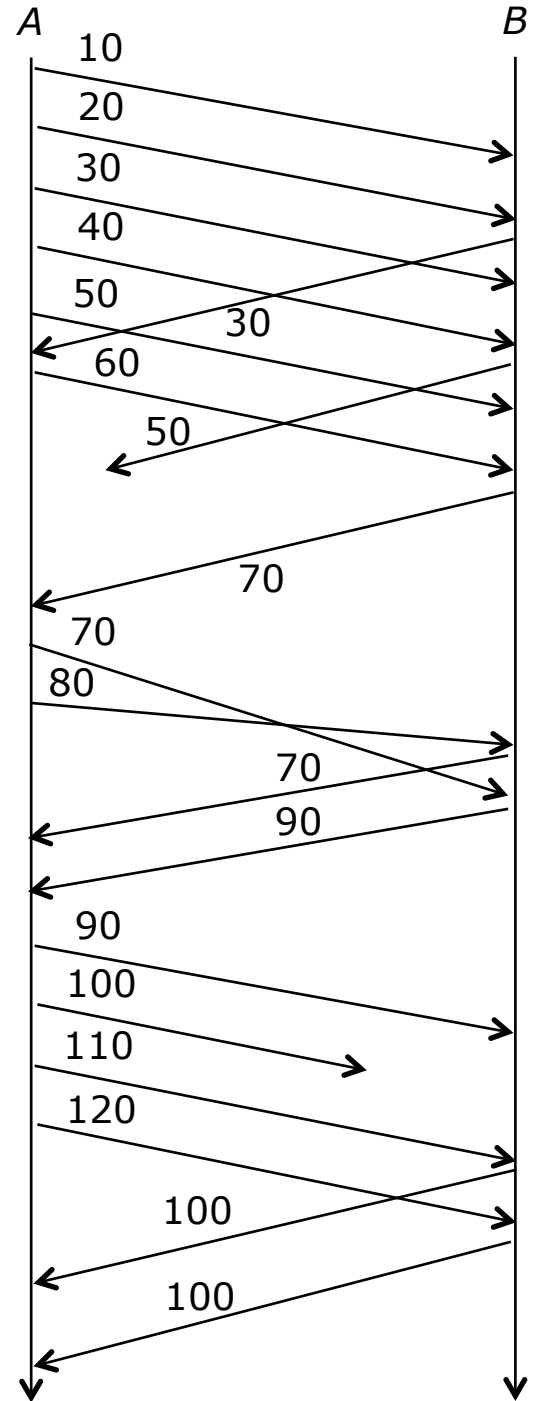

5. (10 points) The diagram at right shows two TCP senders at left and the corresponding receivers at right. Both senders use TCP *Tahoe*. Assume that the MSS is 1 KB, that the one-way propagation delay for both connections is 100 ms and that the link joining the two routers has a bandwidth of 16 Mb/s. Let $cwnd_1$ and $cwnd_2$ be the values of the senders' congestion windows. What is the smallest value of $cwnd_1+cwnd_2$ for which the link joining the two routers stays busy all the time?

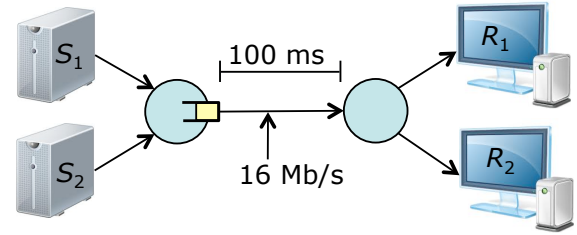

16 Mb/s is 2 MB/s or 400 KB per RTT. So $cwnd_1+cwnd_2=400$ KB is the smallest amount that keeps the link busy.

Assume that the link buffer overflows whenever $cwnd_1+cwnd_2 \geq 600$ KB and that at time 0, $cwnd_1=500$ KB and $cwnd_2=100$ KB. Approximately, what are the values of $cwnd_1$ and $cwnd_2$ one RTT later? Assume that all losses are detected by triple duplicate ACKs.

they are both 1 KB

At this point, what are the values of $ssthresh_1$ and $ssthresh_2$?

$ssthresh_1=250$ KB and $ssthresh_2=50$ KB

After 20 more RTTs, approximately what are the values of $cwnd_1$ and $cwnd_2$?

After 8 RTTs $cwnd_1$ is about 250 KB, so after 20, it is about 262 KB. After 6 RTTs $cwnd_2$ is about 50 KB, so after 20, it is about 64 KB.

Approximately, how many more RTTs before $cwnd_1+cwnd_2 \geq 600$ KB again?

$262+64=326$, so it will take $(600-326)/2 = 274/2 = 137$ RTTs before $cwnd_1+cwnd_2 \geq 600$ KB again.

6. (10 points). Let A be a router with neighbors B , C and D in a network that uses RIP. The table at right shows the routing table at A , including the hop-count information used by RIP.

prefix	output	next hop	hop count
1.2.1.*	1	-	1
1.2.2.*	2	B	2
1.2.3.*	2	B	3
1.2.4.*	3	C	2
1.2.5.*	3	C	3
1.2.6.*	3	C	4
1.2.7.*	4	D	2
1.2.8.*	4	D	3

Based on this information, how many links does a packet need to pass through on its way from A to a host with address 1.2.5.37?

3 hops

Assume that the network has been stable for a long time. Let h be the hop count for the path from router D to a host in subnet 1.2.6.*. Is it possible that $h=2$? Why or why not?

No. If D could reach a host in 1.2.6. in 2 hops, then A could reach it in 3 hops by going through D . But the table shows that the best path from A has length 4 and goes through C .*

Is it possible that $h=8$? Why or why not?

No. Since D is A 's neighbor, D can be at most 5 hops away from a host in 1.2.6..*

Suppose that A sends a RIP packet to C . List all the prefixes that A advertises in this packet (remember that RIP uses poisoned reverse). Show the hop count sent by A for each advertised prefix.

(1.2.1.,1), (1.2.2.*,2), (1.2.3.*,3),
 (1.2.4.*,15= ∞), (1.2.5.*,15= ∞), (1.2.6.*, 15= ∞),
 (1.2.7.*,2), (1.2.8.*,3)*

7. (10 points) The diagram at right shows a switched Ethernet LAN with two routers (labeled Q and R), seven switches and five hosts. The switches are configured with three VLANs and the labels on the links show the VLANs that are active on those links (note, some links are active in multiple VLANs).

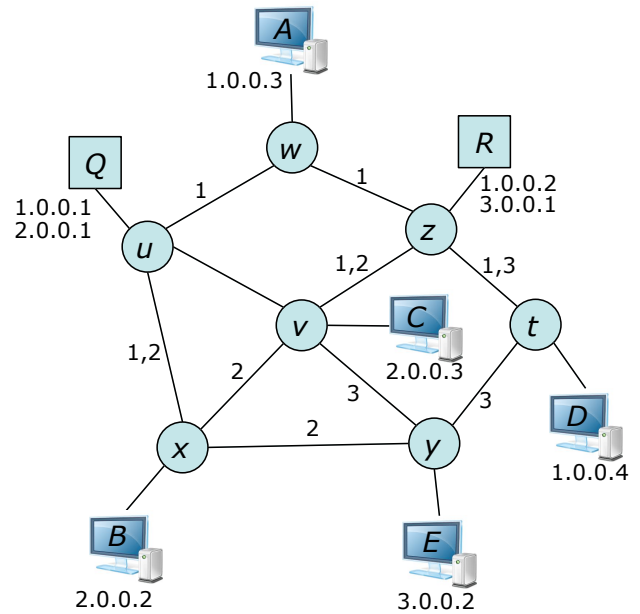

Each VLAN is assigned an IP subnet, specifically, VLAN 1 is assigned subnet 1.0.0.0/8, VLAN 2 is assigned subnet 2.0.0.0/8 and VLAN 3 is assigned subnet 3.0.0.0/8. The two routers each belong to two subnets and can send/receive packets using two VLAN ids, while each of the hosts is configured in the VLAN that corresponds to its IP subnet.

If host B sends a packet to host C, what switches and routers does the packet pass through? List them in order, repeating any switches that the packet passes through more than once.

x and v

If host A sends a packet to host B, what switches and routers does it pass through.

w, u, Q, u, x

If B sends a packet to E, what switches and routers does it pass through.

x, u, Q, u, w, z, R, z, t, y

If C is transferring a large file to E while B is transferring a large file to D, what data rate would they each get, assuming that the switch links are all 1 Gb/s?

Because they have some links in common, they would each get 500 Mb/s

What bandwidth would they get if E were in subnet 2.0.0.0/8?

In that case, they would each get 1 Gb/s